

# **SINGER**

**81-1,2,3,4,5,6,8,9,20,21,22**

# INSTRUCTIONS

FOR USING

# SINGER SEWING MACHINES

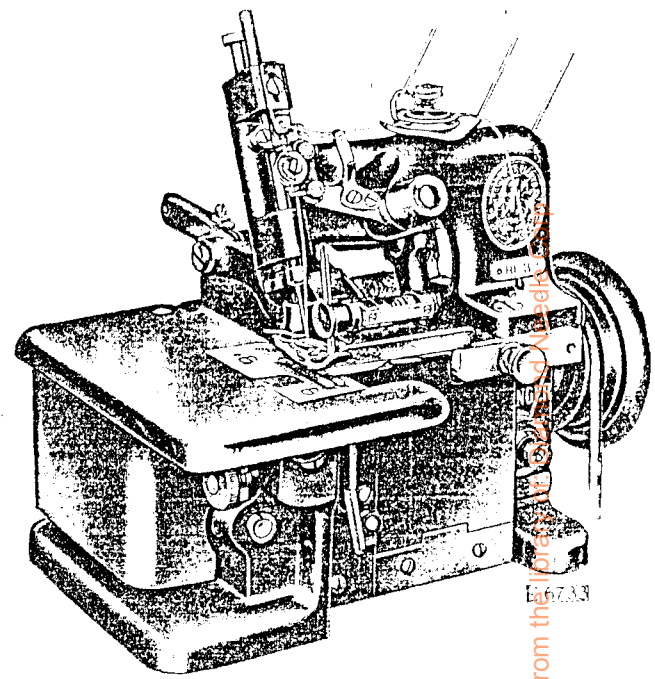

From the Library of the University of Toronto

OF

## CLASS 81-

FOR OVEREDGING

### THE SINGER MANUFACTURING CO.

## SINGER

### MANUFACTURING SEWING MACHINE OIL

(Cloth and Leather)

For Repairs

or

### MANUFACTURING SEWING MACHINE OIL

Scissors, White Goods

where a standard oil is desired

These special sewing machine oils are the result of a long and careful study of the requirements of the various types of sewing machines and are the best for their use.

### THE IMPORTANCE OF USING SINGER NEEDLES FOR SEWING MACHINES

The best sewing results will be obtained by using the needles furnished by The Singer Sewing Machine Company.

Singer needles can be purchased from any Sewing Shop for the Manufacturing Trade.

Genuine Singer needles should be used in Singer machines. Others will not give the same results. Marked with the Singer name and the Singer logo.

Needles and bobbins marked for Singer machines are not Singer-made needles.

Copyright 1922 by The Singer Manufacturing Company. All rights reserved in all countries.

**INSTRUCTIONS**  
FOR  
**ADJUSTERS AND MACHINISTS**

**To Set the Needle Bar at the Correct Height**

Turn the balance wheel over from you until the needle bar has risen  $\frac{3}{32}$  inch from its lowest position. The point of the left hand looper, on its loop taking stroke, should then be at the centre of the needle, and the eye of the needle should be about  $\frac{1}{16}$  inch below the looper point. If the needle bar is not at the correct height, loosen the pinch screw (K2, Fig. 2) and move the needle bar upwardly or downwardly as required, then securely tighten the pinch screw (K2).

**To Change the Stroke of the Needle Bar**

A variation in the amount of needle bar stroke can be obtained by adjusting the ball stud (U, Fig. 3). To lengthen the stroke, loosen the set screw (V, Fig. 3) and move the ball stud inwardly or toward the crank. To shorten the stroke of the needle bar, move the ball stud (U) outwardly or away from the crank, then securely tighten the set screw (V).

**To Set the Left Hand Looper**

Turn the balance wheel over from you until the needle bar is in its lowest position. The looper point should then be about  $\frac{1}{32}$  inch to the left of the needle. Now turn the balance wheel until the needle bar has risen  $\frac{3}{32}$  inch from its lowest position and the point of the looper should be at the centre of the needle.

The left hand looper (C2, Fig. 8) should be set in the looper carrier (W, Fig. 8) so that the point of the looper on its loop taking stroke just brushes the needle. The point of the right hand looper or spreader should pass at the recess back of the left hand looper eye as closely as possible without touching it.

A variation in the amount of the looper motion can be obtained by adjusting the ball stud (N, Fig. 2). To increase this motion, loosen the set screw (M, Fig. 2) and move the ball stud (N, Fig. 2) inwardly or toward the crank. To decrease the motion, move the ball stud outwardly or away from the crank. After the desired motion has been obtained, securely tighten the set screw (M, Fig. 2).



The size of the needle to be used should be determined by the size of the thread which must pass freely through the eye of the needle. If rough or uneven thread is used, or if it passes with difficulty through the eye of the needle, the successful use of the machine will be interfered with.

Orders for needles must specify the *quantity* required, the *size* number, also the *class* and *variety* numbers separated by the letter x.

The following is an example of an intelligible order:

"100 No. 18, 81 x 5 Needles."

The best stitching results will be obtained in using the needles furnished by the Singer Sewing Machine Company.

### To Oil the Machine

To ensure easy running and prevent unnecessary wear of the parts which are in movable contact, the machine requires oiling and when in continuous use, it should be oiled at least twice each day.

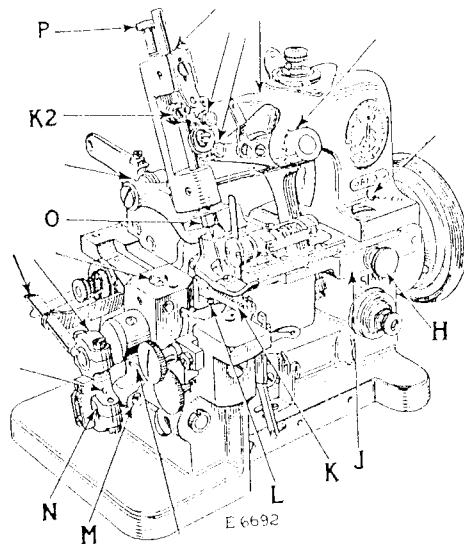

FIG. 2. OILING POINTS AT THE FRONT OF THE MACHINE  
ALSO ADJUSTMENTS ON THE MACHINE

Oil should be applied to all oil holes marked "Oil" and to all oiling places indicated by arrows in Figs. 2 and 3.

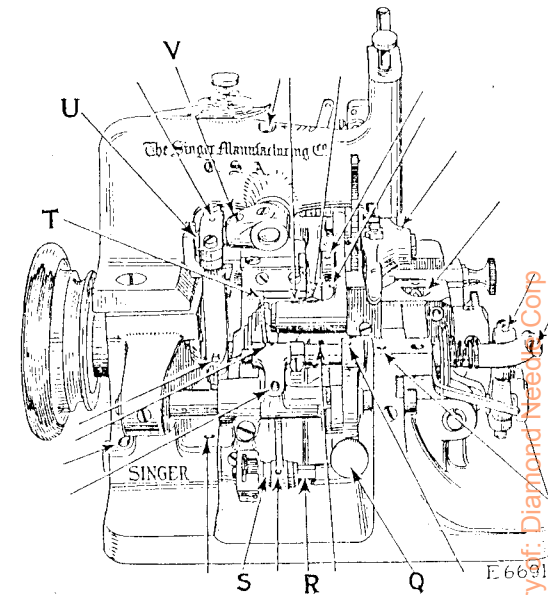

FIG. 3. OILING POINTS AT THE BACK OF THE MACHINE  
ALSO ADJUSTMENTS ON THE MACHINE

### To Set the Needle

Needles of Class 81x have two grooves, one on each side; they are also ground out above the eye on one side.

Loosen the clamping nut (O, Fig. 2) at the lower end of the needle bar and put the needle up into the bar as far as it will go, with the ground-out side at the back, or farthest from you. Then tighten the clamping nut (O).

## To Thread the Needle

(SEE FIG. 4)

Pass the thread from the unwinder, from front to back through the top hole (1) in the tension bracket, down and from back to

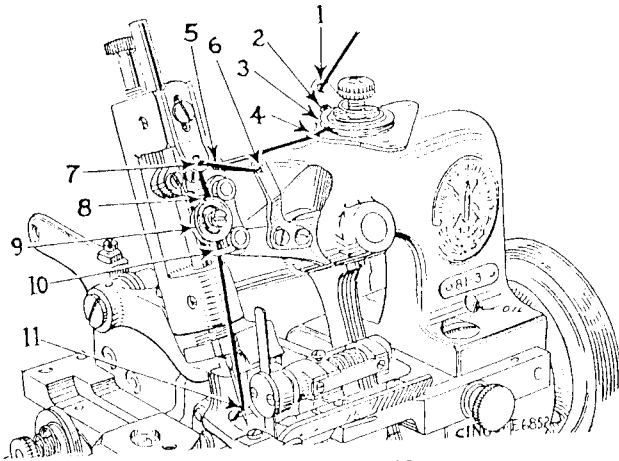

FIG. 4. THREADING THE NEEDLE

front through the lower hole (2) in the tension bracket, from right to left around and between the tension discs (3), to the left through the hole (4), from back to front through the hole (5) in the needle bar connecting bracket, then from back to front through the hole (6) in the thread take-up lever and from front to back through the hole (7) in the thread controller, down to the right of the pin (8), around the left side between the retainer discs (9), down into the guide (10) of the needle bar thread retainer bracket, then from front to back through the eye of the needle (11).

NOTE: When threading the needle in Machines 81-2, 81-5, 81-7, 81-9, 81-10, 81-11, 81-12, 81-13, 81-14, 81-20, 81-21 and 81-23, the thread should be omitted from the hole (5) in the needle bar connecting bracket. The thread should be passed directly from the hole (4) to the hole (6).

Machines 81-8 and 81-16 have no take-up for the needle thread. On Machine 81-8 the thread should be passed directly from the hole (4) to the hole (7). On Machine 81-16 the thread should be passed from the hole (4) to the left through the right hand hole in front of the controller wire, to the left through the left hand hole of the thread controller.

## To Thread the Left Hand Looper

Pass the thread from the unwinder, through the hole at the back of the machine base, from back to front under the projecting piece

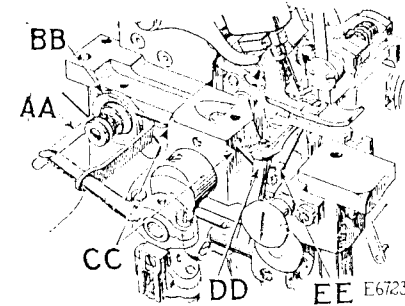

FIG. 5

(AA, Fig. 5) of the oil tube bracket, up over and between the tension discs (BB, Fig. 5), toward you through the thread tube (CC, Fig. 5), to the right and behind the spreader lever (DD, Fig. 5), from back to front through the take-up (EE, Fig. 5) up and from back to front through the hole (FF, Fig. 6) in the head of the looper, to the right and from front to back through the eye (GG, Fig. 6) near the point of the looper.

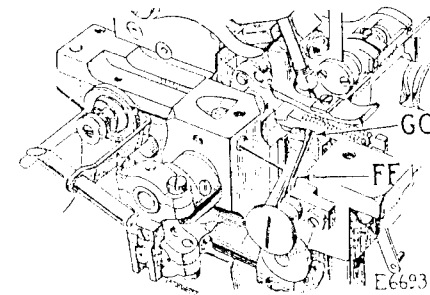

FIG. 6

NOTE: Machines 81-2, 81-5, 81-7, 81-9, 81-22 and 81-23 have a thread pull-off (D, Fig. 11) at the back of the machine under the work plate, and Machine 81-12 has a thread pull-off above the work plate. When threading these machines, pass the thread from the unwinder through the thread pull-off as shown in Fig. 11, then continue as instructed above.

Machines 81-2, 81-5, 81-22 and 81-23 have a thread nipper (G, Fig. 11) for the left hand looper thread. When making the three-thread, single purl stitch on any of these machines, the thread should be passed from the tension discs (BB), between the nipper blades (G, Fig. 11) and through the thread tube (CC).

## To Thread the Right Hand Loooper

(SEE FIG. 7)

Pass the thread from the unwinder, upwardly through the right hand hole (A) in the tension bracket, down through the thread guide

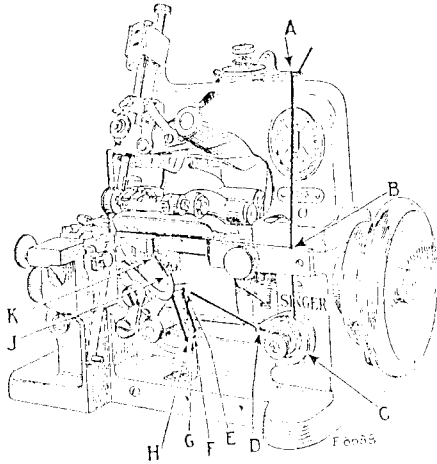

FIG. 7

(B), down around and between the tension discs (C), left through the hole (D) in the tension bracket, from back to front into the eye of the thread take-up (E), down under the back hook (F), to the left of the prong (G) and under the front hook (H) of the thread staple, up and from back to front through the hole (J) in the heel of the looper, then from back to front through the eye (K) near the point of the looper.

NOTE: Machines 81-2, 81-5, 81-7, 81-9, 81-16, 81-20, 81-21, 81-22 and 81-23 have a thread pull-off (B, Fig. 11) at the top of the needle bar connecting rod. When threading any of these machines, have the thread pass down through the hole (A, Fig. 11) in the tension bracket, through the hole in the pull-off (B), then up through the hole (C, Fig. 11) in the tension bracket and continue as previously instructed.

## To Regulate the Length of Stitch

The length of stitch is regulated by the feed regulator (S, Fig. 3). With the wrench provided, loosen the screw stud (R, Fig. 3) and move the regulator backward or forward until the indicator (T, Fig. 3) points to the number, on the indicator plate, designating the required stitch. Then securely tighten the screw stud (R).

On machines having no stitch indicator, move the regulator outwardly to increase the length of stitch or inwardly to decrease the length of stitch. When the desired length of stitch has been obtained, securely tighten the screw stud (R).

## To Change the Style of Stitch

**To make the two-thread stitch**, using a looper and a spreader, the take-up for the needle thread should be set to the left so as to draw most of the thread on the downward stroke, leaving about  $\frac{1}{16}$  inch to be drawn through the tension on the upward stroke. The small take-up on the looper lever should be set to the right so as to draw most of the thread on the downward stroke, and the tension adjusted so as to draw the purl to the edge.

**To make a single purl stitch**, using two loopers and three threads, the needle thread is drawn tightly to the goods, making a firm seam when two pieces are stitched together, and a very narrow bight can be used without danger of the seam pulling out. When adjusting the machine for this stitch, the needle thread is omitted from its take-up, the thread being passed directly from the tension bracket to the thread guide on the arm head and a tight tension is used. The small take-up on the looper lever at the left is set to the right so as to draw all the thread on the downward stroke, and the tension on the left hand looper thread is made very light. Sufficient tension is used on the right hand looper thread to bring the purl to the edge.

**To make the double purl stitch**, using two loopers and three threads, the machine must be threaded in the regular way, the needle thread take-up set so as to draw most of the thread on the downward stroke and a medium or light tension used, the small take-up on the looper lever set as far as it will go to the left or turned at right angles, bringing the hooked portion toward the operator. Medium tension is used on the left hand looper thread. The tension on the right hand looper thread must be strong enough to bring the purl to the edge.

## To Regulate the Tensions

The appearance of the stitch is largely governed by the tensions and the size and quality of the different threads. The softer threads when used in the loopers, produce the most pleasing stitch.

## To Regulate the Pressure on the Material

The pressure on the material is regulated by means of the thumb screw (P, Fig. 2). To increase the pressure, turn this thumb screw downwardly. To decrease the pressure, turn the thumb screw upwardly.

20 Dan Kralik  
Singer 81-

To all whom it may concern:

The placing or renewal of the name "Singer" (Reg. U. S. Pat. Off.) or any of the trade marks of The Singer Manufacturing Company on any machine that has been repaired, rebuilt, reconditioned or altered in any way whatsoever outside a Singer factory or an authorized Singer agency is forbidden.

#### Purchasing of Parts and Needles

Supplies of parts and needles for Singer machines can be purchased at any Singer Shop for the Manufacturing Trade or ordered by mail. If orders are sent by mail, money or a post office order covering their value, including postage, should be enclosed and the order will then be promptly filled and forwarded by mail or express.

Genuine Singer Needles should be used in Singer Machines. These Needles and their Containers are marked with the Company's Trade Mark "SIMANCO." 1

Needles in Containers marked "For Singer Machines" are not Singer made needles. 2

#### DESCRIPTION

Machines of Class 81- are for covering the edges of knit or woven fabrics, leather, felt, etc., with a two-thread or three-thread overedge chain stitch as desired.

Machines fitted for making the three-thread chain stitch can be changed to make the two-thread chain stitch by substituting a spreader for the right hand looper.

Machines fitted for making the two-thread chain stitch can be changed to make the three-thread chain stitch by substituting a looper for the spreader and applying tension complete, tension thread guide, staple and take-up, with their fastening screws.

The trimming machines of this class trim the edges of the goods in advance of the stitching so that the article can be shaped while it is being stitched.

#### Speed

The maximum speed recommended for Machines of Class 81- is 3300 stitches per minute, with the exception of Machines 81-10, 81-12, 81-14 and 81-16, which make 3000 stitches per minute. The machines should be run slower than the maximum speed until the parts which are in movable contact have become glazed by their action upon each other. When the machines are in operation, the balance wheel should always turn over from the operator.

#### Needles

Needles for Machines of Class 81- are of the Class and Variety numbers as given in the following table.

MACHINES	CLASS AND VARIETY NOS. OF NEEDLES	SIZES OF NEEDLES
81-2 81-3 81-4 81-6 81-13 81-14 81-20 81-21 81-22 81-23	81 x 1	9, 11, 14, 16, 18, 19, 21
81-1 81-8 81-11	81 x 3	16, 18, 19, 21
81-5 81-10 81-12	81 x 5	14, 16, 17, 18, 19, 21, 22, 23, 24, 25
81-7 81-9	81 x 11	18, 19, 21
81-16	81 x 7	9, 11, 13, 14, 16, 18

From the library of: Diamond Needle Co.

### To Adjust the Trimmer

The lower knife (X, Fig. 8) should always be fastened in position when removing or replacing the upper knife. The lower

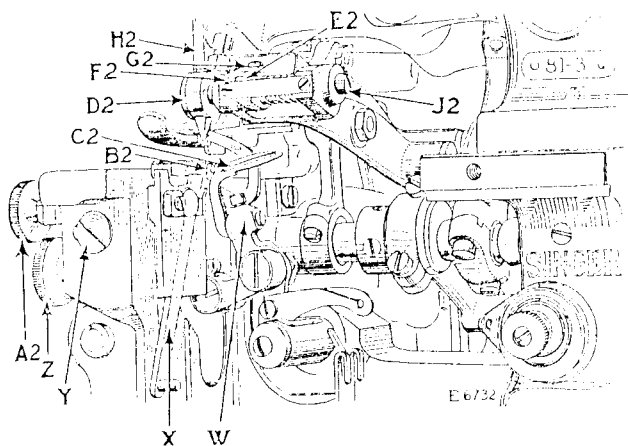

FIG. 8

knife is adjustable to the right or left and its position governs the position of the upper one, also the width of bight on the goods.

To take out the lower knife (X, Fig. 8), loosen the thumb screw (A2, Fig. 8) and press the upper knife holder (D2, Fig. 8) toward the balance wheel, then draw the knife out downwardly. To replace the lower knife, have the presser foot and feed down, press the upper knife holder toward the balance wheel, and push the lower knife upwardly so as to touch the presser foot without lifting it, or so that it is just flush with the top of the throat plate, then tighten the thumb screw (A2, Fig. 8). To adjust the trimmer sidewise, loosen the thumb screw (H, Fig. 2) and move the extension bracket (J, Fig. 2) to the right or away from the upper knife, loosen the screw (Y, Fig. 8) and turn the thumb screw (Z, Fig. 8) inwardly or outwardly until the trimmer is in the desired position, then securely tighten the screw (Y). Move the extension bracket (J, Fig. 2) back toward the upper knife, leaving just enough clearance between the upper knife and the bracket so as to allow free movement of the upper knife, then tighten the thumbscrew (H, Fig. 2).

To remove the upper knife (H2, Fig. 8), loosen the screw (J2, Fig. 8) at the end of the knife holder, press the knife holder (D2) toward the balance wheel and remove the knife. When replacing the knife, have the knife holder in its lowest position and pressed toward the balance wheel, insert the knife and set it so that its cutting edge is just below the cutting edge of the lower knife, then tighten the clamping screw (J2).

### To Adjust the Upper Knife Tension

To adjust the tension on the upper knife, loosen the set screw (G2, Fig. 8) and move the knife holder guide (E2, Fig. 8) toward the balance wheel until the distance between the knife lever (F2, Fig. 8) and the guide (E2, Fig. 8) is equal to the thickness of the upper knife when the knives are in contact with each other, then securely tighten the set screw (G2).

### To Change the Trimming Margin of Machine 81-4

To change the trimming margin, push the lever (L2, Fig. 9) to the right or toward the balance wheel until the end of the

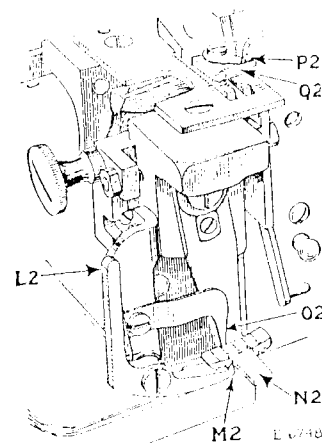

FIG. 9

lever (M2) disengages the notch in the regulating lever (N2, Fig. 9). Move the regulating lever (N2) to the right or left until the indicator (O2, Fig. 9) points to the desired number on the regulating lever. Release the lever (L2), permitting the end of the lever to enter the notch in the regulating lever to retain the adjustment.

**NOTE:** When the trimming margin is changed it is sometimes necessary to re-adjust the chaining-off finger on the presser foot.

For a wide bight, move the adjusting lever (P2, Fig. 9) to the left notch on the presser foot (Q2, Fig. 9). For a narrow bight set the lever in the notch at the right on the presser foot.



### To Sharpen the Knives

Knife Grinder 41335, illustrated below, is recommended for sharpening the knives. As one grinder will serve for several machines,

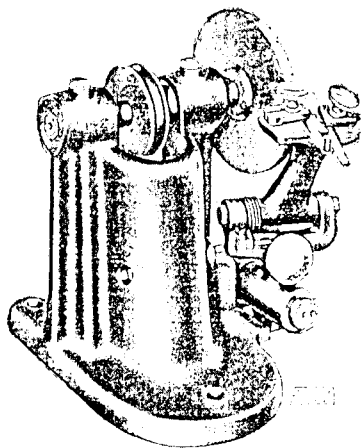

FIG. 10. KNIFE GRINDER 41335 FOR MACHINES 81-1, 81-2, 81-3, 81-4, 81-5, 81-6, 81-8, 81-9, 81-20, 81-21 AND 81-22

it is not included as part of the machine and must be ordered separately. The use of this grinder ensures the correct angle and shape of the cutting edge of both knives.

Knife Grinder 41819 is used for sharpening the knives of Machines 81-7 and 81-23.

### To Raise or Lower the Feed Dogs

The feed dog (K, Fig. 2) should be set so that when it is raised to its highest point by the feed lifting eccentric the full depth of the teeth will project above the throat plate. The feed dog (K) can be set at the desired height after loosening the screw (L, Fig. 2). When the feed dog is set at the required height, securely tighten the screw (L).

When very elastic materials are to be sewn on any of the following machines: 81-3, 81-4, 81-6, 81-7, 81-20 and 81-21, the back feed dog (B2, Fig. 8) should remain in its raised position only long enough to permit the work to come out flat. To adjust the back feed (B2), turn the adjusting thumb screw (Q, Fig. 3) inwardly to lengthen its duration of feed and outwardly to shorten its duration of feed.

### To Adjust the Rear Feed Dog on Machine 81-22

The height of the rear feed dog on Machine 81-22 may be changed by loosening the clamping screw (F, Fig. 11) and moving

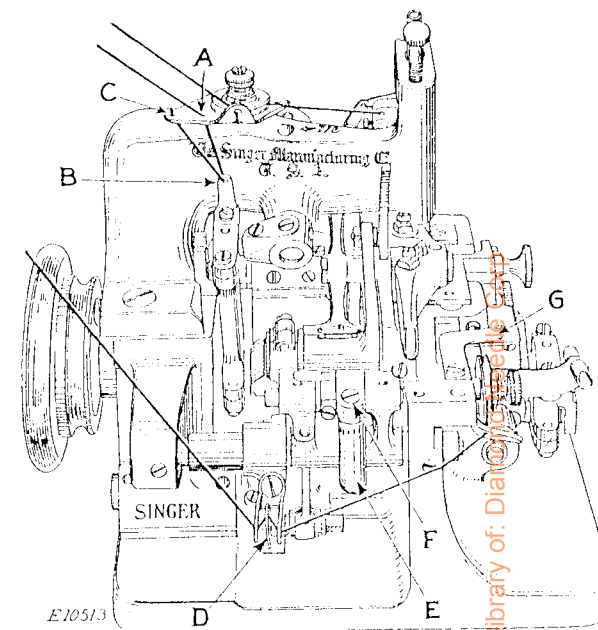

FIG. 11

the lever (E, Fig. 11) up or down. For more stretching of the material as it leaves the needle, the lever (E) should be moved upward. To prevent stretching, or to produce a gathering effect, move the lever downward. The screw (F) should then be tightened to prevent this adjustment from changing.